



Direct-acting 2 way standard solenoid control valve

- Excellent range
- Very good response
- Compact valve design
- Orifice sizes 2...9.5 mm
- Optional: Explosion-protected coil

Type 2875 can be combined with...



Type 8605

Control Electronics,
Cable plug version



Type 2508

Cable plug



Type 8611

Universal controller



The direct-acting solenoid control valve Type 2875 is used as the regulating unit in control loops. Due to an elastomeric seat seal the valve closes tight (integrated shut-off function), up to the DN specific nominal pressure. The plunger of the valve is assembled frictionless, which leads to an extraordinary adjustment characteristic. This valve is particularly suitable for demanding control tasks (high control range, dry gases, etc.).

Circuit function A

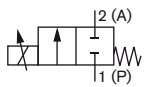

2/2 way direct-acting,
solenoid proportional
control valve

Valve control takes place through a PWM signal¹⁾. The duty cycle of the PWM signal determines the coil current and hence the position of the plunger. Optionally the valve can also be driven with DC voltage.

Please note the sizing comments for such a control valve on page 2.

¹⁾ PWM pulse width modulation

²⁾ Pressure data [bar]: Measured as overpressure to the atmospheric pressure, orifice further depends on nominal pressure

³⁾ Maximum value, value depends on operating pressure

⁴⁾ Characteristic data of control behaviour depends on process conditions

⁵⁾ By flow measurement

Technical data - Valve	
Body material	Brass, stainless steel
Seal material	FKM, EPDM on request
Medium	Neutral gases, liquids on request
Pressure range	0...25 bar ²⁾
Medium temperature	-10...+90 °C
Ambient temperature	max. +55 °C
Power supply	24 V DC
PWM frequency	900 Hz
Power consumption	16 W
Max. coil current³⁾	750 mA
Duty cycle	100 % continuously rated
Port connection	G 3/8, G 1/2, NPT 3/8, NPT 1/2
Electrical connection	Tag connector (DIN EN 175301-803 Form A)
Installation	As required, preferably with actuator in upright position
Typical control data at PWM-Control⁴⁾	
Hysteresis	< 5 %
Repeatability	< 0.5 % FS ⁵⁾
Sensitivity	< 0.25 % FS ⁵⁾
Span	1:200
Response time (10 -90 %)	25 ms
Protection class - valve	IP65

The valve control can take place through the control electronics of Type 8605, which converts an analogue input signal into a PWM signal.

Further functional features of the Type 8605 electronic control unit:

- Temperature compensation for coil heating by internal current regulation
- Simple adaptation of zero and span settings
- Ramp function to dampen fast set point changes

Characteristics of a solenoid control valve

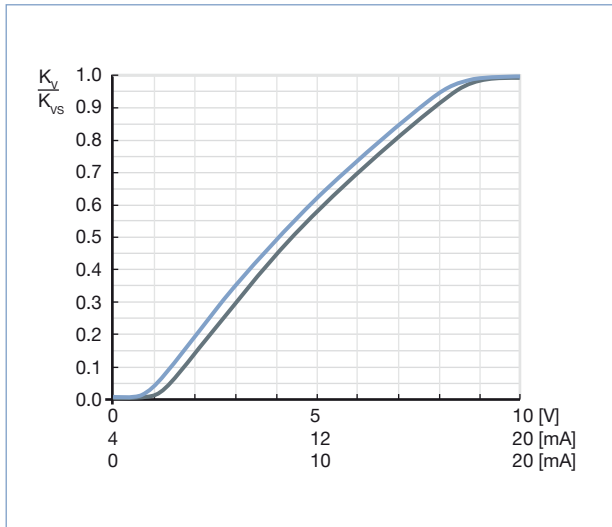

Advice for valve sizing

In continuous flow applications, the choice of an appropriate valve size is much more important than with on/off valves. The optimum size should be selected such that the resulting flow in the system is not unnecessarily reduced by the valve. However, a sufficient part of the pressure drop should be taken across the valve even when it is fully opened.

Recommended value: $\Delta p_{\text{valve}} > 25\%$ of total pressure drop within the system

Otherwise, the ideal, linear valve curve characteristic is changed. If the differential pressure (difference between inlet and outlet pressure) exceeds half the value of the nominal pressure, the characteristics may change.

For that reason take advantage of Bürkert competent engineering services during the planning phase!

Determination of the k_v value

Pressure drop	k_v value for liquids [m ³ /h]	k_v value for gases [m ³ /h]
Subcritical $p_2 > \frac{p_1}{2}$	$= Q \sqrt{\frac{\rho}{1000 \Delta p}}$	$= \frac{Q_N}{514} \sqrt{\frac{T_1 \rho_N}{p_2 \rho}}$
Supercritical $p_2 < \frac{p_1}{2}$	$= Q \sqrt{\frac{\rho}{1000 \Delta p}}$	$= \frac{Q_N}{257 p_1} \sqrt{T_1 \rho_N}$

k_v	Flow coefficient	[m ³ /h] ⁶⁾
Q_N	Standard flow rate	[m ³ /h] ⁷⁾
p_1	Inlet pressure	[bar] ⁸⁾
p_2	Outlet pressure	[bar] ⁸⁾
Δp	Differential pressure $p_1 - p_2$	[bar]
ρ	Density	[kg/m ³]
ρ_N	Standard density	[kg/m ³]
T_1	Medium temperature	[(273+t)K]

⁶⁾ measured for water, $\Delta p = 1$ bar, over the value

⁷⁾ At reference conditions 1.013 bar and 0 °C (273K)

⁸⁾ Absolute pressure

Dimensions [mm] - standard version

Threaded version

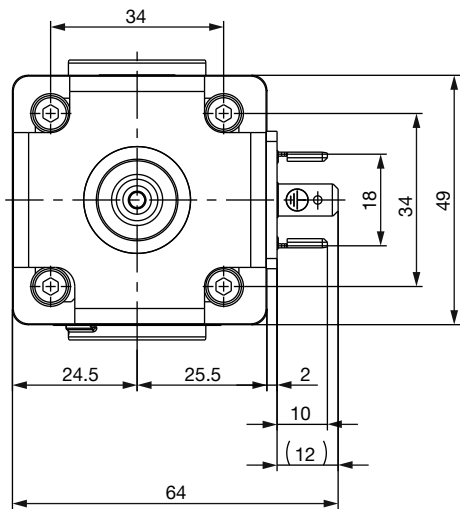
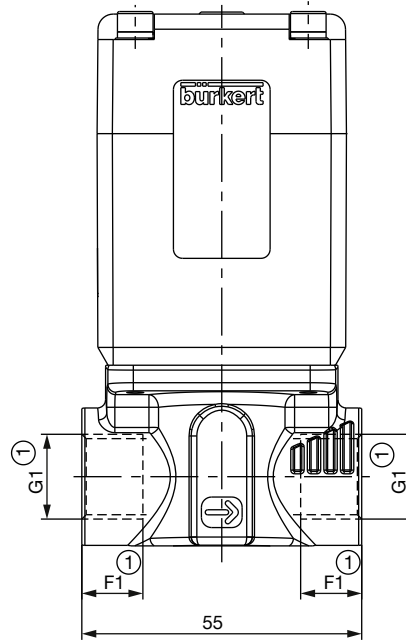
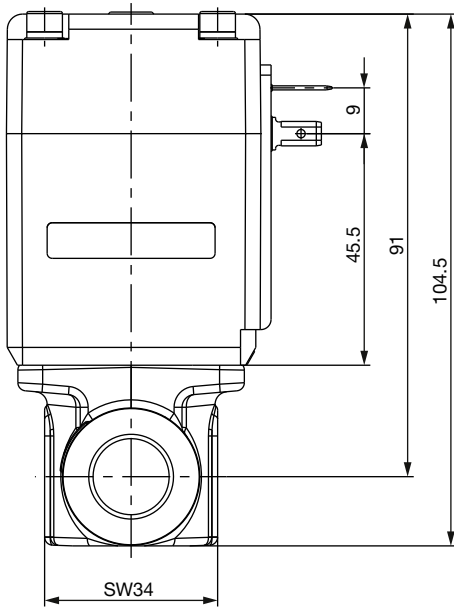
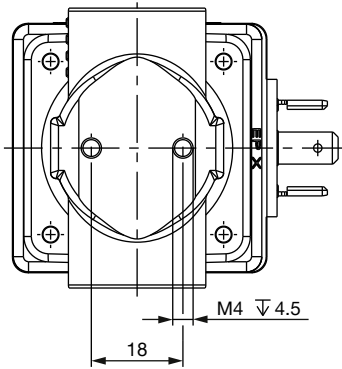

① For G threads the mass
F1 and D1 apply
For NPT threads the mass
F2 and D2 apply

Version	F1	G1	F2	G2
Thread	12	G 3/8	10.3	NPT 3/8
	14	G 1/2	13.7	NPT 1/2

Dimensions [mm] - standard version

Subbase version

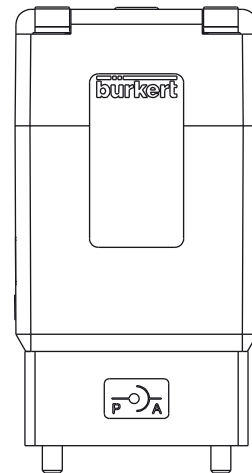
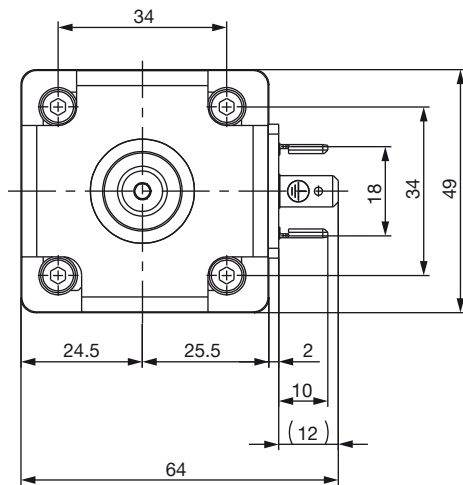
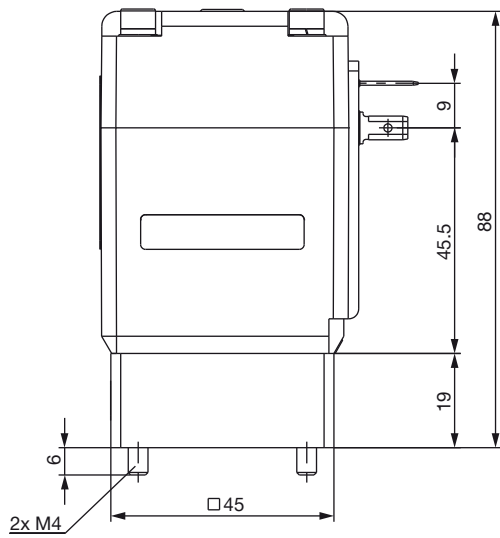
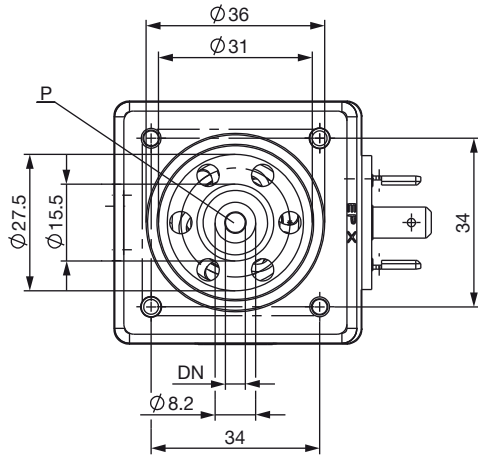

Abmessungen [mm] - ATEX-Ausführung

Threaded version

Version	F1	G1	F2	G2
Thread	12	G 3/8	10,3	NPT 3/8
	14	G 1/2	13,7	NPT 1/2

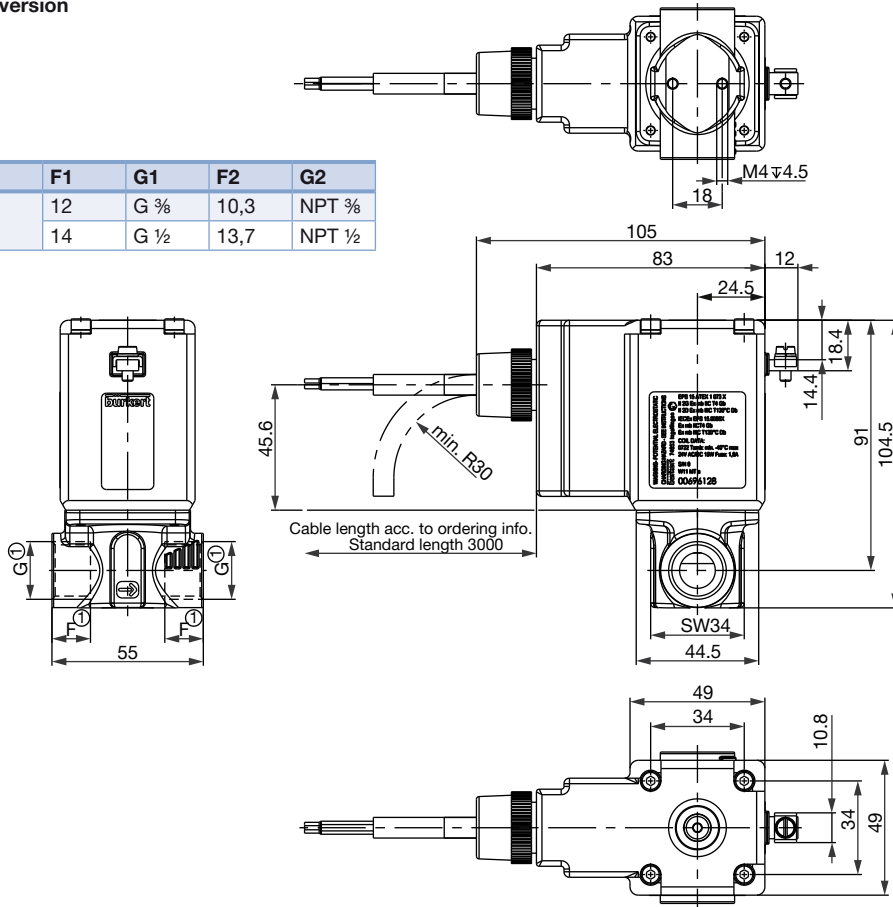

Subbase version

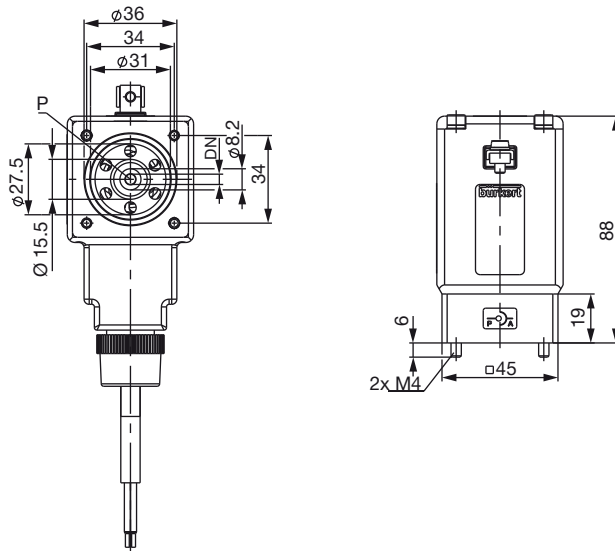

Ordering chart

All valves with FKM seal

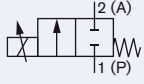
Circuit function	Orifice [mm]	Port connection	k_{vs} value water [m ³ /h] ⁹⁾	Nominal pressure [bar] ¹⁰⁾	Max. differential pressure [bar]	Article no. brass	Article no. Stainless steel
A 2/2 way Normal closed (NC) 	2	G 3/8	0.12	25	12.5	236897	236899
		NPT 3/8	0.12	25	12.5	236898	236900
	3	G 3/8	0.25	10	5	236901	236903
		NPT 3/8	0.25	10	5	236902	236904
	4	G 3/8	0.45	8	4	236905	236910
		NPT 3/8	0.45	8	4	236908	236912
	6	G 1/2	0.45	8	4	236906	236911
		NPT 1/2	0.45	8	4	236909	236913
	8	G 1/2	0.80	4	2	236915	236919
		NPT 1/2	0.80	4	2	236917	236921
	9.5	G 1/2	1.10	2	1	236922	236924
		NPT 1/2	1.10	2	1	236923	236925
	9.5	G 1/2	1.40	0.7	0.35	273004	314557
		NPT 1/2	1.40	0.7	0.35	314555	314559

⁹⁾ k_{vs} value: Flow rate value for water, measured at +20 °C and 1 bar pressure differential over a fully opened valve.

¹⁰⁾ Pressure data [bar]: Overpressure with respect to atmospheric pressure, with a differential pressure (difference between inlet and outlet pressure) above half of the nominal pressure there are discontinuities in the valve's characteristics possible.

Note: Please note that the valves are delivered without control electronics, Type 8605, and cable plug (see ordering chart for accessories).

Ordering chart - variants with approvals

All valves with FKM seal

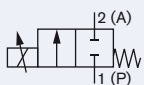
Circuit function	Orifice [mm]	Approvals ¹¹⁾	Port connection ¹²⁾	k_{vs} value water [m ³ /h]	Nominal pressure [bar]	Max. differential pressure [bar]	Article no. brass	Article no. Stainless steel
A 2/2 way Normal closed (NC) 	2	UR	G 3/8	0.12	25	12.5	274976	274988
			NPT 3/8	0.12	25	12.5	274977	274989
		DVGW	G 3/8	0.12	5	5	314262	on request
		ATEX / IECEx	G 3/8	0.12	20	10	291483	on request
	3	UR	G 3/8	0.25	10	5	274978	274990
			NPT 3/8	0.25	10	5	274979	274991
		DVGW	G 3/8	0.25	5	5	314265	on request
		ATEX / IECEx	G 3/8	0.25	9	4.5	291485	on request
	4	UR	G 3/8	0.45	8	4	274980	274992
			NPT 3/8	0.45	8	4	274981	274993
		DVGW	G 3/8	0.45	5	4	314267	on request
		ATEX / IECEx	G 3/8	0.45	7	3.5	291486	on request
	6	UR	G 1/2	0.45	8	4	274982	274994
			NPT 1/2	0.45	8	4	274983	274995
		DVGW	G 1/2	0.80	4	2	274984	274996
		ATEX / IECEx	G 1/2	0.80	4	2	274985	274997
	8	UR	G 1/2	0.80	4	2	314269	on request
			ATEX / IECEx	G 1/2	0.80	3.5	1.75	291487
DVGW		G 1/2	1.10	2	1	274986	274998	
ATEX / IECEx		G 1/2	1.10	2	1	274987	274999	
9.5	UR	G 1/2	1.10	2	1	314270	on request	
		ATEX / IECEx	G 1/2	1.10	1.5	0.75	291488	on request

¹¹⁾ Approvals:

UR (UL recognized)

DVGW - Approval acc. to the European gas device guidelines (DIN EN 161)

ATEX - II 2 G Ex mb IIC T4 Gb ; II 2 D Ex mb IIIC T130°C Db

IECEX - Ex mb IIC T4 Gb ; Ex mb IIIC T130°C Db

¹²⁾ Port connections: Others on request.

Ordering chart - variants for higher differential pressure

All valves with FKM seal

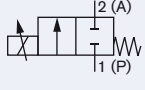
Circuit function	Orifice [mm]	Approvals ¹¹⁾	Port connection ¹²⁾	k_{vs} value water [m ³ /h]	Nominal pressure [bar]	Article no. brass	Article no. Stainless steel	
A 2/2 way Normal closed (NC) 	2.0		G 3/8	0.12	25	239040	239085	
		UR	G 3/8	0.12	25	275000	275005	
		ATEX / IECEx	G 3/8	0.12	20	291468	on request	
	3.0			G 3/8	0.25	10	239086	239087
		UR	G 3/8	0.25	10	275001	275006	
	3.0	ATEX / IECEx	G 3/8	0.25	9	291470	on request	
		4.0		G 3/8	0.45	8	239088	239089
	UR		G 3/8	0.45	8	274090	274091	
	4.0	ATEX / IECEx	G 3/8	0.45	7	291474	on request	
		6.0		G 1/2	0.80	4	239090	239091
	UR		G 1/2	0.80	4	275002	275007	
	6.0	ATEX / IECEx	G 1/2	0.80	3.5	291476	on request	
		8.0		G 1/2	1.10	2	239092	239093
	UR		G 1/2	1.10	2	275004	275008	
	8.0	ATEX / IECEx	G 1/2	1.10	1.5	291477	on request	
9.5			G 1/2	1.40	0.7	291586	314558	

Note: The following technical data changes compared with the data on page 1

- PWM frequency 500 Hz, span 1:100.
- Other connection variations (sub-base, NPT) on request
- For $\Delta p > 145$ PSI it is possible to get inconsistencies in the characteristic curve because of flow conditions in the application.

¹¹⁾ Approvals:

UR (UL recognized)
 DVGW - Approval acc. to the European gas device guidelines (DIN EN 161)
 ATEX - II 2 G Ex mb IIC T4 Gb ; II 2 D Ex mb IIIC T130°C Db
 IECEx - Ex mb IIC T4 Gb ; Ex mb IIIC T130°C Db

¹²⁾ Port connections: Others on request.

Ordering chart for accessories

Cable plug 2508 acc. to DIN EN 175301-803 Form A

The delivery of a cable plug includes the flat seal and fixing screw

Circuitry	Voltage / frequency	Article no.
None	0...250 V AC/DC	008376
None, with 3 m cable	0...250 V AC/DC	783573

Control electronics, Type 8605

Please see datasheet

Further versions on request

 **Material**
EPDM

 **Analytical**
Oxygen version Parts oil-, fat- and silicon free

 **Approvals**
UR (UL recognized)
DVGW/ Gas device guidelines
ATEX / IECEx

 **Port connection**
flange connections

Design data for solenoid control valves

▶ Please fill out this form and send to your local Bürkert Sales Centre* with your inquiry or order

Company	Contact person
Customer No	Department
Address	Tel./Fax
Postcode/Town	E-mail

<input type="checkbox"/> = Mandatory fields	<input type="text"/> Quantity	<input type="text"/> Requested delivery date
Process data		
Medium	<input type="text"/>	
State of medium	<input type="checkbox"/> liquid	<input type="checkbox"/> gaseous
Medium temperature	<input type="text"/> °C	
Maximum flow rate	$Q_{nom} =$ <input type="text"/>	Unit: <input type="text"/>
Minimum flow rate	$Q_{min} =$ <input type="text"/>	Unit: <input type="text"/>
Inlet pressure at nominal operation	$p_1 =$ <input type="text"/>	barg
Outlet pressure at nominal operation	$p_2 =$ <input type="text"/>	barg
Max. inlet pressure (nominal pressure)	$p_{1max} =$ <input type="text"/>	barg
Ambient temperature	<input type="text"/> °C	
Additional specifications		
Body material	<input type="checkbox"/> Brass	<input type="checkbox"/> Stainless steel
Seal material	<input type="checkbox"/> FKM	<input type="checkbox"/> other <input type="text"/>

Note: Please state all pressure values as **overpressures with respect to atmospheric pressure** [barg].

Standard series of solenoid control valves



Type 2871
Orifice 0.05 to 2 mm
20 mm coil width



Type 2873
Orifice 2 to 8 mm
32 mm coil width



Type 2875
Orifice 2 to 9.5 mm
49 mm coil width

To find your nearest Bürkert facility, click on the orange →

www.burkert.com

In case of special application conditions, please consult for advice.

Subject to alteration.
© Christian Bürkert GmbH & Co. KG

1806/6_EU-en_00895222